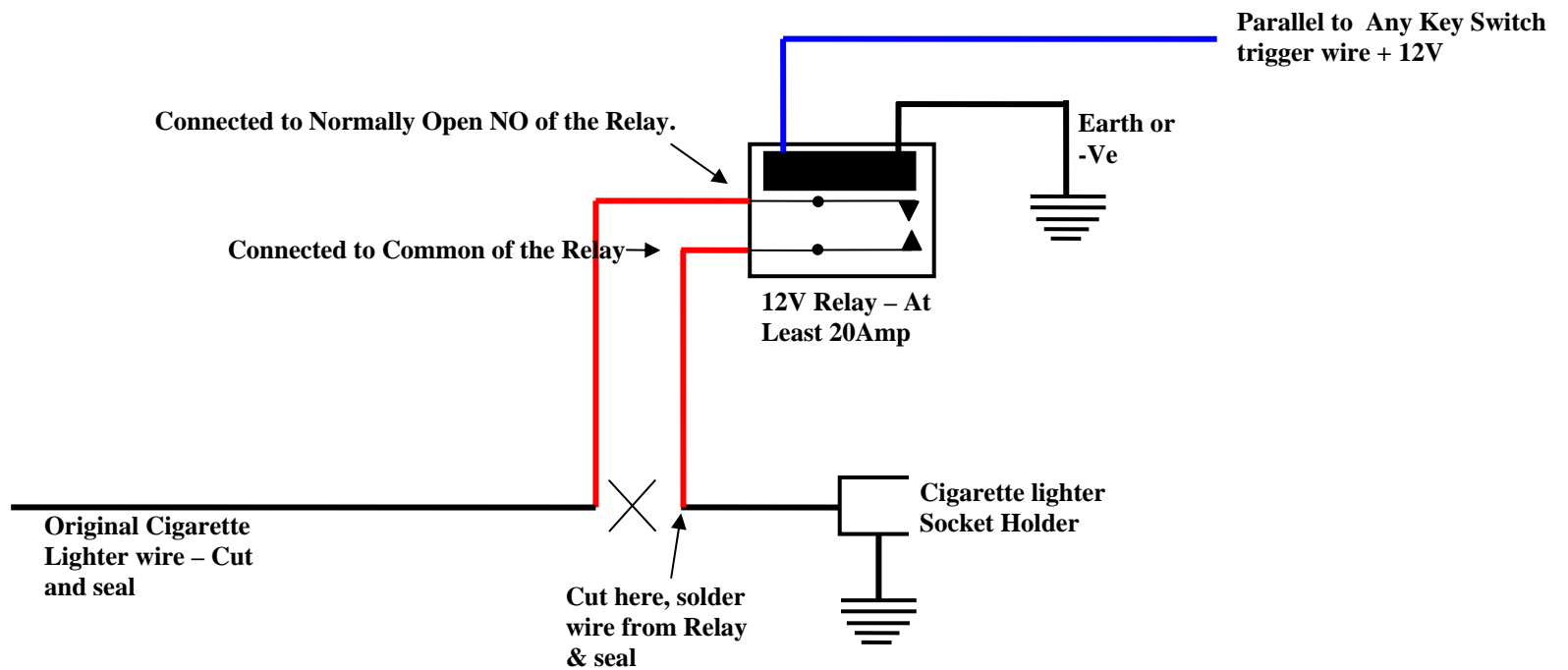

**DIAGRAM A  
CONNECTION**



**EXTRA WIRE AND RELAY CONNECTION REQUIRED WHEN ---  
After Installation of the Plug in Booster, If the Alarm Encounter Problem – Auto lock  
can not function or alarm can not switch on immediately after engine switch off.**